

TO-252 PACKAGE OUTLINE : LINE 06

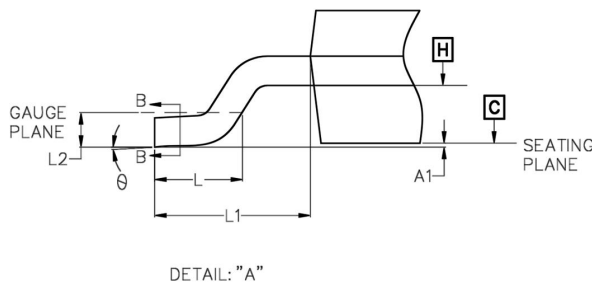
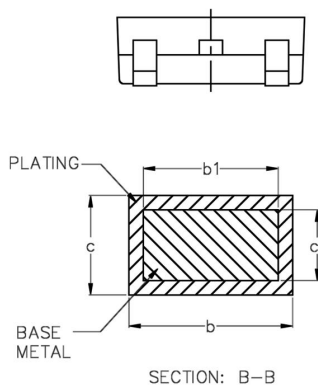
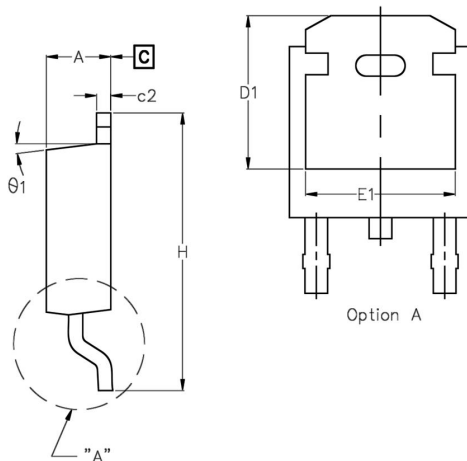
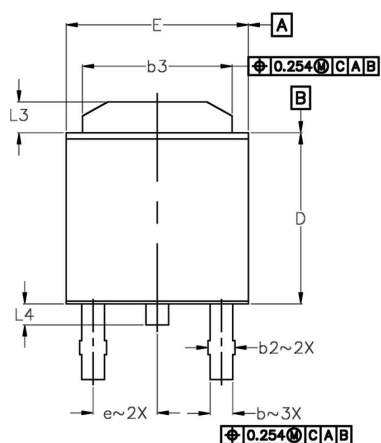

SYMBOL	COMMON			
	MM		INCH	
	MIN.	MAX.	MIN.	MAX.
A	2.184	2.387	0.086	0.094
A1	—	0.127	—	0.005
b	0.750	0.890	0.029	0.035
b1	0.750	0.860	0.029	0.034
b2	0.762	1.143	0.030	0.045
b3	4.953	5.461	0.195	0.215
c	0.460	0.610	0.018	0.024
c1	0.410	0.559	0.016	0.022
c2	0.460	0.889	0.018	0.035
D	5.969	6.223	0.235	0.245
D1	5.207	—	0.205	—
E	6.350	6.731	0.250	0.265
E1	4.318	—	0.170	—
e	2.290 BSC		0.090 BSC	
H	9.398	10.414	0.370	0.410
L	1.397	1.778	0.055	0.070
L1	2.743 BSC		0.108 BSC	
L2	0.508 BSC		0.020 BSC	
L3	0.889	1.270	0.035	0.050
L4	—	1.016	—	0.040
θ	0°	10°	0°	10°
θ1	0°	15°	0°	15°

(UNIT:mm)

RECOMMENDED LAND PATTERN (UNIT:mm)

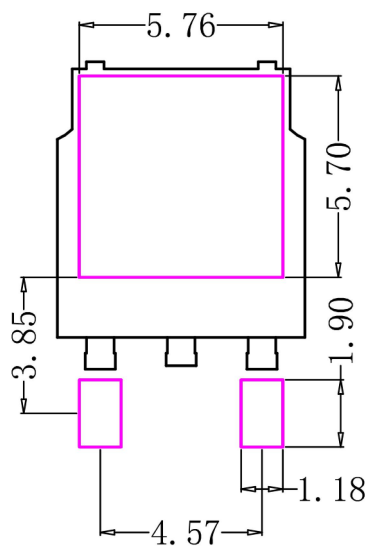

SCALE 5:1

TO-252 PACKAGE OUTLINE : LINE 83

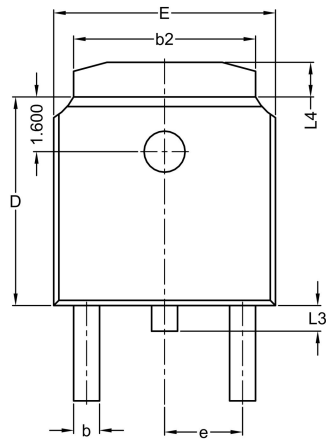

TOP VIEW

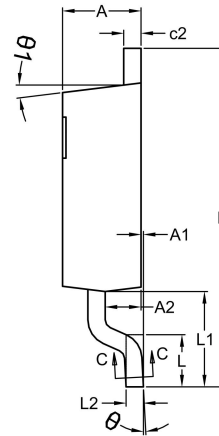

SIDE VIEW(Right)

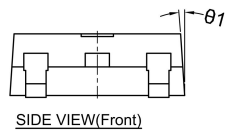

SIDE VIEW(Front)

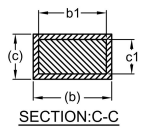

SECTION:C-C

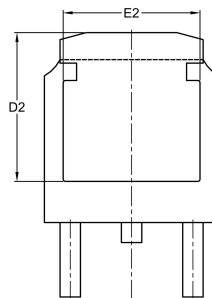

OPTION 1
BOTTOM VIEW

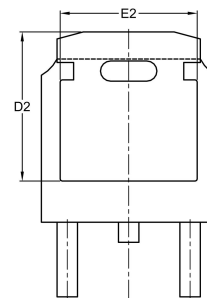

OPTION 2
BOTTOM VIEW

DIM SYMBOL	MIN.	NOM.	MAX.
A	2.200	2.300	2.400
A1	0.000	0.070	0.130
A2	0.950	1.050	1.150
b	0.700	0.800	0.900
b1	0.660	0.760	0.860
b2	5.134	5.334	5.534
c	0.448	0.548	0.648
c1	0.458	0.508	0.558
c2	0.448	0.548	0.648
D	6.000	6.100	6.200
D2	5.372	5.572	5.772
E	6.400	6.500	6.600
E2	4.900	5.100	5.300
e	2.286 BSC.		
H	9.700	9.900	10.100
L	1.380	1.525	1.725
L1	2.588	2.788	2.988
L2	0.508 BSC.		
L3	0.600	0.750	0.950
L4	0.812	1.012	1.212
θ	1°	3°	5°
θ1	6°	7°	8°

(UNIT:mm)

RECOMMENDED LAND PATTERN (UNIT:mm)

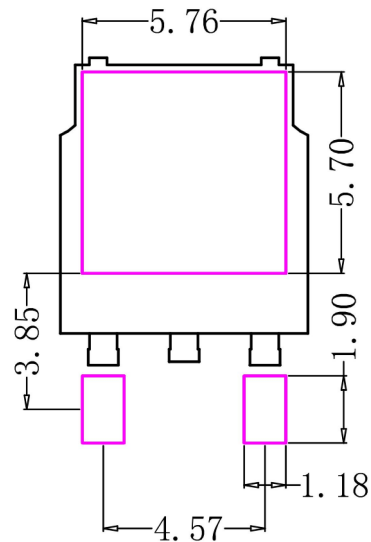

SCALE 5:1