

SOT-23-3 PACKAGE OUTLINE

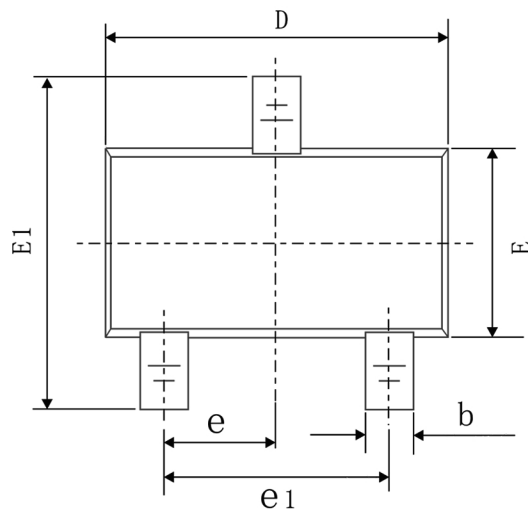

TOP VIEW

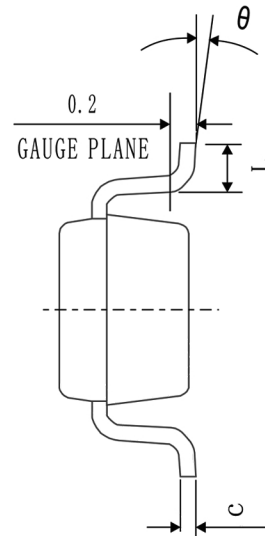

SIDE VIEW

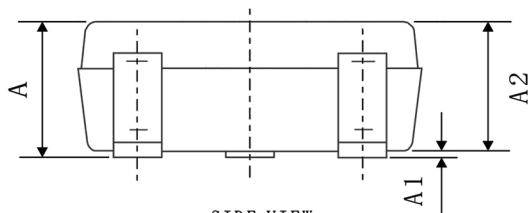

SIDE VIEW

RECOMMENDED LAND PATTERN

(UNIT:mm)

SYMBOL	MIN	NOM	MAX
A	---	---	1.30
A1	0.00	0.05	0.10
A2	1.00	1.10	1.20
b	0.30	0.40	0.50
c	0.10	0.125	0.15
e1	1.80	1.90	2.00
D	2.80	2.90	3.00
E	1.50	1.60	1.70
E1	2.60	2.80	3.00
L	0.30	0.45	0.60
θ	0°	4°	8°
e	0.95BSC		

(UNIT:mm)

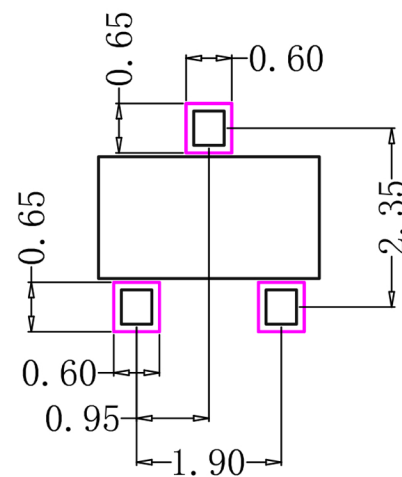

SCALE 10:1